

Installation Instructions:

Trackility Hydraulic Damper Kit for Fanatec CSL Elite V2

1.

Required Tools:

The only tools required for installation are those provided with your Fanatec CSL Elite V2 pedals:

- 4mm hex-head wrench (allen key)
- 13mm spanner

Note: Remove the cap from at least one side of your pedals.



2.

Remove **rear** threaded bar from pedals. This can sometimes be tight to remove/replace. Take your time.

The front threaded bar should remain in place.

Note: Always remove the Trackility unit before adjusting pedal spacing, as front threaded bar will bind with toe of foot for secure fit.



3.
Slide the Tracktivity unit into the recess behind the load-cell. This will be a tight fit as the toe of the unit engages with the front threaded bar.

The heel of the unit should be flush with the back of the pedal set and the rear holes aligned with the threaded bar.

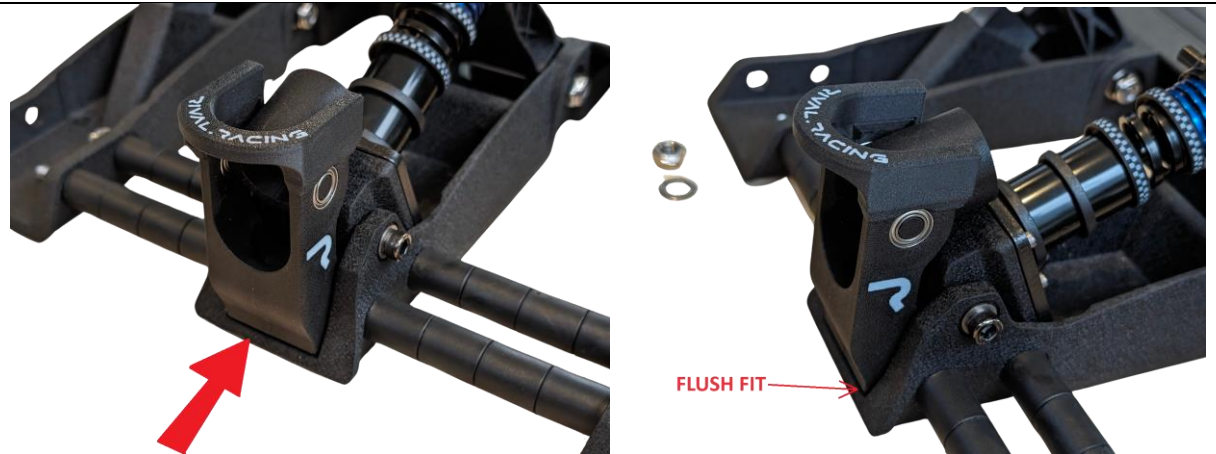

4.
Replace rear threaded bar, nuts, and cap.

This can be tight on first fitment. Ensure the threaded bar holes are aligned with the holes on the Tracktivity unit.

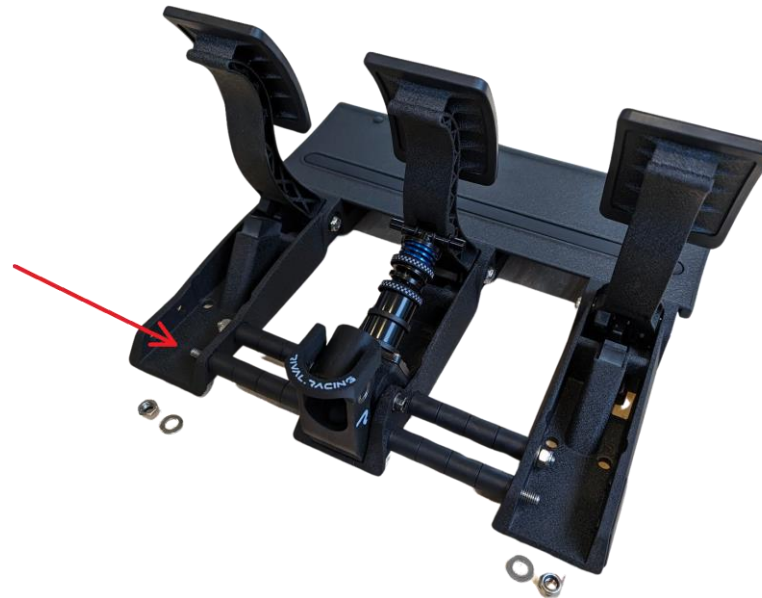

5.
Install the wishbone with the cup facing outwards.
Wishbone will 'click' into place.



6.
Install the hydraulic damper.
a. Ensure the damper is set to between 0 to 1 to ease compression.
b. Lower the damper into place.
c. Compress damper and place into cup of wishbone.

Note: To remove damper, ensure unit is set between 0 to 1 and compress by hand and remove damper. Do not attempt to remove damper in higher setting.

WARNING: To avoid discomfort and risk of pinching skin, ensure damper is set to between 0 to 1 before compressing and fitting to cup.



7.
Adjust Fanatec brake settings.

Although the Tracktivity unit is isolated from the load-cell, it is recommended to re-calibrate your brake pedal sensitivity after re-fitting or changing springs/elastomers.

Note: The Fanatec Tracktivity unit allows for 30mm of damper travel (approx. 45mm of brake pedal travel).

If preferred, using a light-sprung setup (i.e. high travel low resistance) you will encounter a firm stop at the end of this travel. If so, you will need to re-calibrate your brake pedal sensitivity to account for the new load at full travel.

The image displays two side-by-side screenshots of the Fanatec software interface, illustrating the process of adjusting brake settings. Both screenshots show a sidebar menu on the left with options like 'Devices', 'Tuning Menu', and 'Settings'. The main area is divided into 'Pedals Values' and 'Pedal Settings | Advanced | Setup 1'.

BEFORE ADJUSTMENT: The 'Pedals Values' section shows Clutch at 0%, Brake at 91%, Throttle at 0%, and Handbrake at 0%. A red 'I' is placed above the Brake bar. In the 'Pedal Settings' section, the 'Combined pedals' toggle is off, '[BRF] Brake Force' is set to 50% (indicated by a red circle and arrow), and '[BLI] Brake Level Indicator' is set to OFF.

AFTER ADJUSTMENT: The 'Pedals Values' section shows Clutch at 0%, Brake at 100%, Throttle at 0%, and Handbrake at 0%. In the 'Pedal Settings' section, the 'Combined pedals' toggle is off, '[BRF] Brake Force' is set to 45% (indicated by a red circle), and '[BLI] Brake Level Indicator' is set to OFF.

8.
Fill out a quick survey!

We are a small company who loves sim racing. If you can spare the time, please complete the survey at this link.

We take all feedback and suggestions (including for new products) seriously, and aim to continually improve our products to give you the edge over your Rivals.

Brake late, trail the entry, and Surpass your Rivals!

Thank you!



[OR, CLICK HERE FOR DIRECT LINK](#)